

NEW

OMRON

**Smart Sensors
ZFV-C**

with Ultra-High-Speed Color CCD Cameras

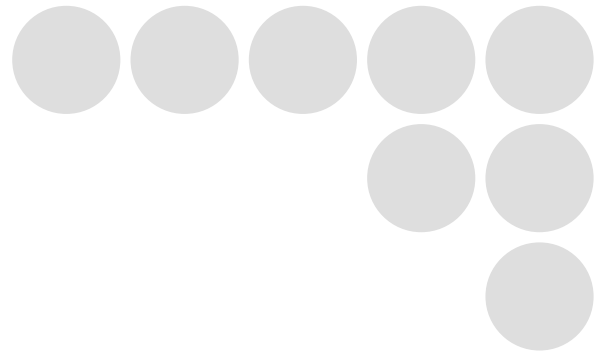

**The Next Generation of Advanced Color Sensing.
For Demanding, Color-Critical Applications.**



realizing



**Have you heard about some
of the sensor problems on
your production lines?**



If you listen carefully,
you'll probably hear people complaining
about these sensor problems.

With optical sensors...

It's difficult to
make fine settings.

Detection is
unstable, leading
to quality
problems.

It's difficult to reset
the line when
products change.

With image sensors...

It takes time to
make settings and
adjustments.

They're
expensive.

Only people with
technical
knowledge can
operate them.



Optical sensors and image sensors.

The general consensus on the production line is that they both have their advantages and disadvantages.

Many users hesitate to introduce a full-scale image sensor system, but at the same time, find it difficult to install and use an optical sensor system.

Now there is a sensor that answers these problems.

Not an optical sensor and not an image sensor, it's a brand new type of smart sensor.

With the increasing importance that is being placed on quality control today, you will find this sensor to be a major help in moving your production lines forward.

Introducing the new Smart Sensor from OMRON.



**Simple to use.
Detection abilities close to
human vision.
Smart Sensor provides the
best combination of optical
and image sensors.**



Color or position differences are a good example.

A person can see these with a glance, but it's both costly and labor-intensive to set up a system that will allow a sensor to detect these differences.

If only there were a simpler way, something that resembled human vision...

Now there is, because we have added color capabilities to the Smart Sensor.

In addition to being able to distinguish colors, the new Smart Sensor also offers stable detection for ordinary, conventional workpieces.

It goes a long way toward answering many of the problems that today's production lines are facing.

Stability

From sensing **points** to sensing **areas**

With optical sensors...

There's a chance they will fail to detect due to problems like a shift in the position of printed text.



The color ZFV!

It distinguishes shapes, so its measurements maintain stability.



The Color Filter function also improves contrast for more stable detection of even faint text.



Reliability

Double-check with **shape** and **color**

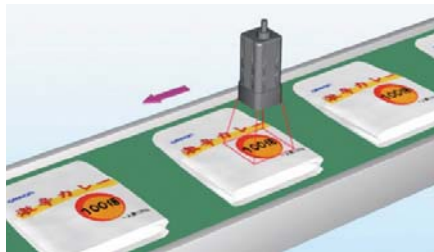

Smart Sensor inspects objects using both shape and color, the two main criteria used by people.

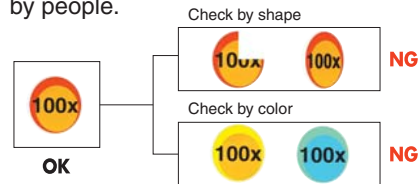

Simplicity

Set-up is **easy**, even for first-time users.

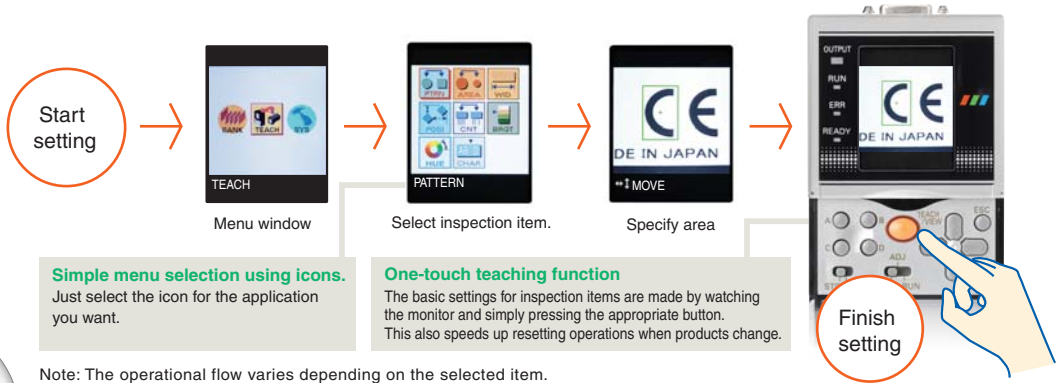

Ease

Easier than **image sensors** in a variety of ways.

With image sensors...

- COST** You need to worry about the initial cost and the work to build the system.
- EASY** You don't need advanced functions for simple inspections.
- AFTER CARE** Settings are complicated and maintenance is a chore.

With smart sensors...

- Start-up is easy because the sensor and the light source are integrated. Of course, it is also reasonably priced.
- Only the functions that your production people truly need are provided. By including the essential functions of the image sensor, we have achieved highly stable measurement.
- Even new users can make settings and adjustments easily by selecting the icons while watching the LCD monitor. You don't have to be an expert to use it.

OMRON Color Technology Provides Superior Sensing.

The original Smart Sensor was designed to be easy enough for anybody to use, and our color model shares the same characteristic. The ZFV-C Color Smart Sensor is designed with the same Target, Teach, Go simplicity as the original ZFV.

The Color Filter function is completely automatic, and colors can be easily extracted while watching the monitor. This sensor is smart enough to handle even advanced applications.

The Automatic Color Filter function adds stability to your images.

This function increases the image contrast to make measurements more stable. There are a total of seven color filters in all. The one that obtains the most suitable contrast is automatically selected, so there's no need to worry about color setting parameters.



Simply choose the candidate color to complete color extraction.

For items that use color extraction, you simply specify the area you want. The color components in that area are then analyzed and the extraction color candidates are automatically displayed. All you have to do is select the color to be measured. The extraction conditions for the candidate colors can also be fine-tuned if necessary. This is OMRON's unique human-machine interface for color extraction.

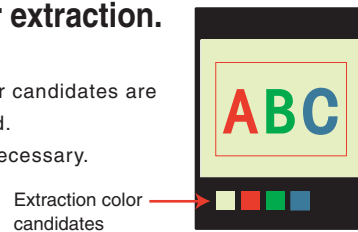

Actual color measurement



Inspecting for the intermixture of different-colored packages

Actual colors can be measured, and those differing from the reference color can be easily distinguished.

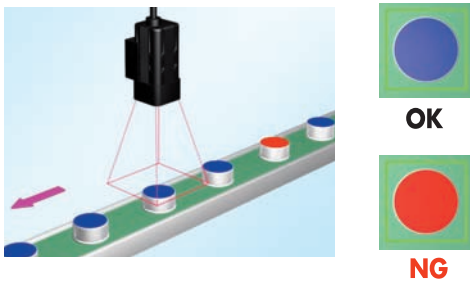

Simultaneous, one-touch checking of multiple colors



Inspecting for the intermixture of different cap types

Multiple colors can be extracted, so that the surface area of each color can be distinguished.

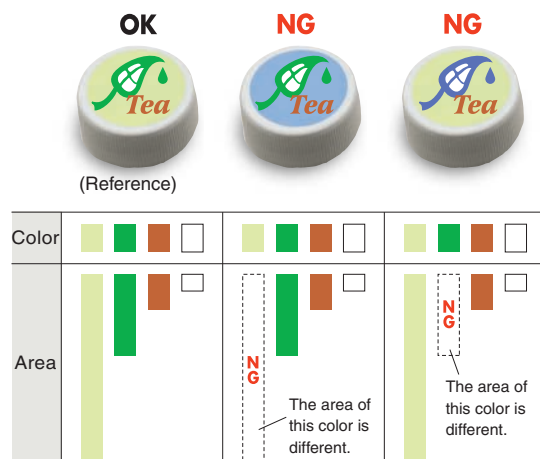

Seven High-level Matching Capabilities for a Wide Range of Applications



Pattern

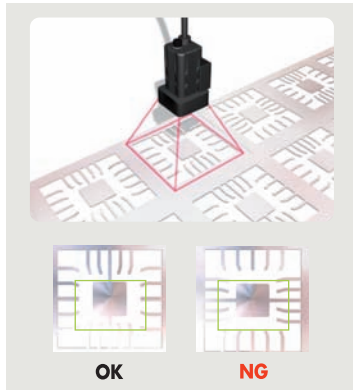

► Measure difference or presence of patterns to match shape of object.



Area

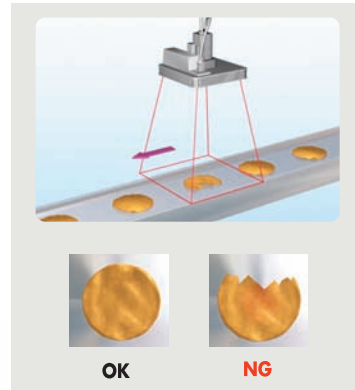

► Measure the area of shapes and compare against model to detect broken cookies.



Position

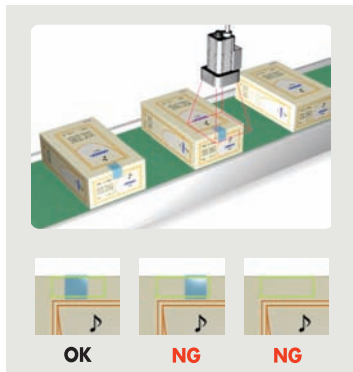

► Measure the edge position of labels or sheets.



Width

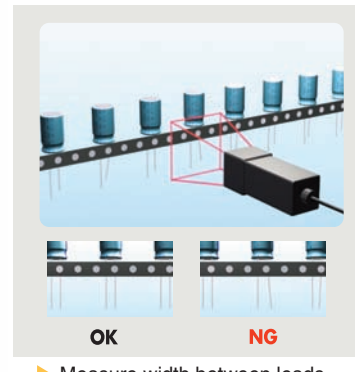

► Measure width between leads.



Number

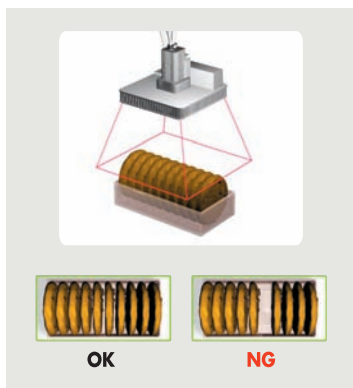

► Count the number of cookies.



Brightness

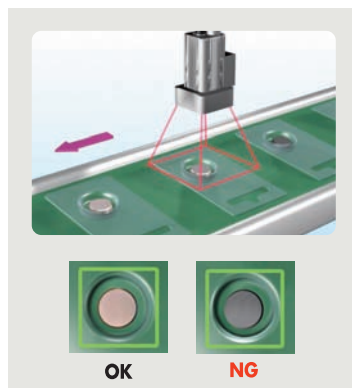

► Detecting dirt on battery surfaces.



Character

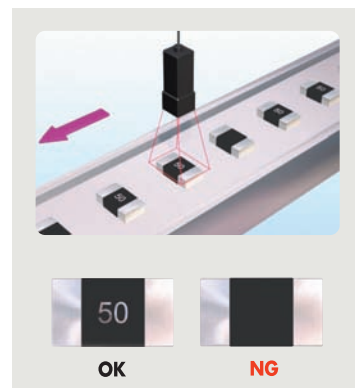

► Match entire character string or detect one missing character.

Additional Special Features

1

Wider Field of View of 150 mm

With an FOV from 5 to 150 mm, you can inspect even large workpieces that could not be previously handled.

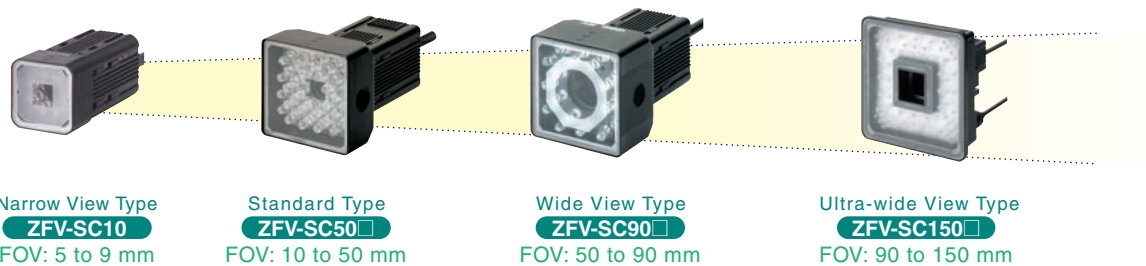

Adjustable View

Simple Focus Adjustment

An easy to use, manual focus adjustment on the camera eliminates the need to change the head or modify programming for different workpiece sizes.

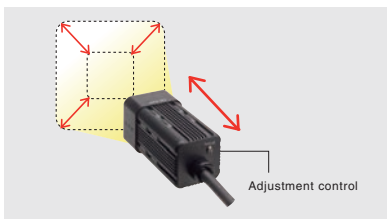

Optimize Lighting Pattern

Intelligent Lighting ZFV-SC10/-SC50/-SC90

The lighting pattern can be varied to ensure a uniformly bright display even when the Sensor Head is mounted at an angle. Also, the light turns in sync with the shutter operation, for excellent stability and a long service life.

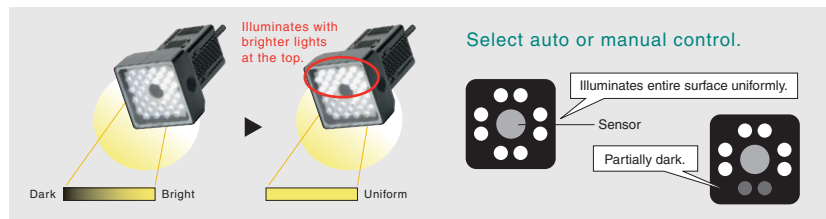

Fast Mounting

Multi-mount Bracket ZFV-SC10/-SC50/-SC90

Mounts to either of the four Sensor Head surfaces, allowing highly flexible mounting and removal.



Ultra Fast for High-speed Production Lines

High-speed Random Shutter CCD

Captures images without any blur, even on high-speed lines. Even at high shutter speeds, the LED power is automatically controlled to provide crisp, clear images.



IP67-compliant Design ZFV-SC90W/-SC150W

Washable Head

Featuring an IP67-equivalent design, these models can be completely immersed in water for washing. The entire structure, including the light source, is water resistant.



High-quality Data Transmission

Digital Interface Capability

The image captured by the Sensor Head is quickly transmitted in digital format, making it immune to noise.



2

Optional Lighting with Easy, One-touch Mounting ZFV-SC50□/SC90□

A wide variety of optional Lighting Units are available for when the light intensity of the integrated lighting is not sufficient, or when through-beam lighting or some other lighting method is required. Simply plug in the connector to add on.

There is also no need for a special power supply for lighting. Plus, the optional Units feature strobe lighting in sync with the Sensor Head shutter, to provide stable lighting for an extended period of time and a long service life.



Bar-type low-angle lighting
ZFV-LTL04

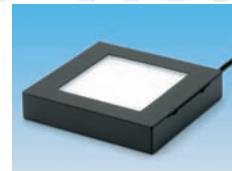

Light source for through-beam lighting
ZFV-LTF01

3

Vision Amplifier with Monitor Features Versatile Functions in a Compact Body

Integrated with a 1.8-inch LCD monitor, this Amp is the same compact size as our monochrome models.

It enables operation while viewing the image, so the measurement status can be checked while the line is moving.

It also features USB and RS-232C interfaces for connection to a personal computer.

Selectable Display Patterns

One-touch Display Selection

Select the image display that is easiest to see from among color, monochrome, and color extraction display patterns.

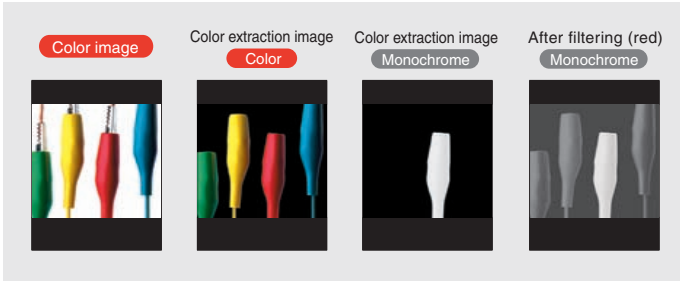

Quick and Easy Operation

Function Keys

Fixed keys are allotted with various functions for easy, one-touch operation.

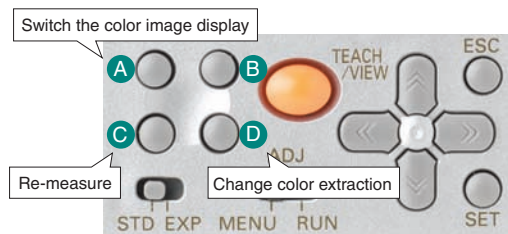

Note: Button B is used for function expansion.

Japanese-English Selection

Multi Menu

The menu can be switched to Japanese or English to match the application.

4

High-speed Color Processing

The processing speed is approximately the same as that for monochrome, even when detecting color images with high precision.

OMRON's image processing technologies remove the usual hesitation to use color processing due to its reduced efficiency.

The Industry's Fastest

Real-time Search

An original CCD drive technology and image processing engine enable ultra-fast response by processing data as the image is being captured. The actual image processing time thus becomes zero, making the total processing speed 13 ms maximum.



Even Faster — 5 ms

Partial Capture Function

The processing speed can be further increased by limiting the image capture to only the part that is required for inspection. Processing requires 8 ms in FAST mode, and 5 ms (max. speed) in MAX mode.

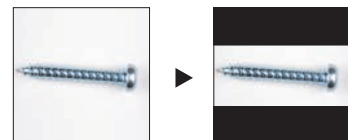

Note: FAST mode

5

Excellent Expandability Meets Even More Applications

With today's rapid pace of new product development, it is essential to select sensors that have future expandability. The Smart Sensor provides the same level of quality control as larger sensor systems, thanks to its newly enhanced application capabilities and data management and analysis.

Flexible Combinations

High-speed Digital Bus Connection

Controllers can now be directly connected to prevent delays in response. By altering the connection, multiple areas can be simultaneously processed, measurement items can be combined, and the output from two Sensor Heads can be integrated. This also provides sufficient response to future workpiece changes.



Convenient for Personal Computer Operation and Management

Smart Monitor ZFV Support Software

This software allows settings and image data to be saved and loaded with a personal computer. For details on the Smart Monitor ZFV Support Software, please contact your OMRON representative.



6

Easy Operation Achieved by Considering the Operator's Viewpoint

In addition to offering easy basic operation, the ZFV has been designed to provide the best possible operation in a variety of situations. It helps your quality control system evolve and become smarter by allowing machines to handle the bothersome tasks.

Handy for Maintenance

I/O Monitor Function

The parallel I/O status can be displayed on the monitor to simplify wiring checks, to make maintenance and system start-up faster and easier.



Visually Check Judgment Settings

Adjustment Mode

Judgment settings are displayed in bar format, so judgment conditions can be intuitively set.



Flexible Controller Installation

Flexible installation meets the specific needs of each production line. In addition to DIN rail mounting, installation is easy in control panels.



Extend the Service Life

ECO Mode

When not in use, the LCD backlight is automatically turned OFF. This greatly extends the service life compared with having the backlight constantly ON.

Versatile Teaching Modes

Freeze-screen Teaching

This function enables easy one-button teaching, using an image of an instantaneous event that was captured with an external trigger.

Workpiece-movement Teaching

The optimum lighting can be automatically selected by using an external trigger to input an image of a moving workpiece.

Ordering Information

Models

Sensor Heads

Appearance	Type	Setting distance	Sensing area	Model
	Narrow View	34 to 49 mm (variable)	5 × 4.6 mm to 9 × 8.3 mm (variable)	ZFV-SC10
	Standard	31 to 187 mm (variable)	10 × 9.2 mm to 50 × 46 mm (variable)	ZFV-SC50 (IP65) ZFV-SC50W (IP67)
	Wide View	66 to 141 mm (variable)	50 × 46 mm (H × V) to 90 × 83 mm (H × V)	ZFV-SC90 (IP65) ZFV-SC90W (IP67)
	Ultra-wide View	114 to 226 mm (variable)	90 × 83 mm (H × V) to 150 × 138 mm (H × V)	ZFV-SC150 (IP65) ZFV-SC150W (IP67)

Amplifier Units

Appearance	Power supply	Output type	Model
	24 VDC	NPN	ZFV-CA40
		PNP	ZFV-CA45

Accessories

Data Storage Units

Appearance	Power supply	Output type	Model
	24 VDC	NPN	ZS-DSU11
		PNP	ZS-DSU41

Controller Link Unit

Appearance	Model
	ZS-XCN

Panel-mounting Adapter

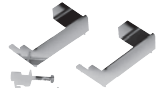



Appearance	Model	
	ZS-XPM1	First Unit
	ZS-XPM2	Additional Units (for expansion)

Sensor Head Extension Cable

Cable length	Model
3 m	ZFV-XC3BV2
3 m	ZFV-XC8BRV2 (Robot cable type)
8 m	ZFV-XC8BV2 (See note 1.)

A maximum of two Extension Cables can be connected to extend the cable length of each Sensor Head. There are no restrictions on the combinations of the two Extension Cables to be used.
 Note 1: The ZFV-XC8BV2 Extension Cable can be used only with ZFV-SC10/SC50/SC50W Sensor Heads.

External Lighting

Appearance	Type	Model
	Bar Lighting	ZFV-LTL01
	Bar Double Lighting	ZFV-LTL02
	Bar Low-angle Lighting	ZFV-LTL04
	Light Source for Through-beam Lighting	ZFV-LTF01

Specifications

■ Sensor Heads

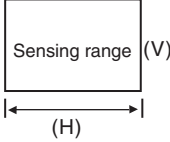
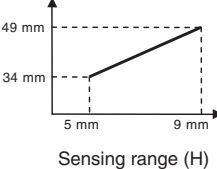
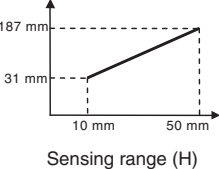
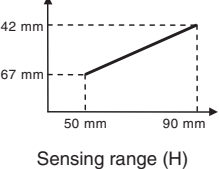
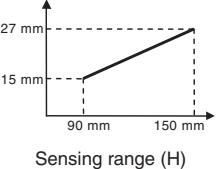
Item	ZFV-SC10 (Narrow View Type)	ZFV-SC50/SC50W (Standard Type)	ZFV-SC90/SC90W (Wide View Type)	ZFV-SC150/SC150W (Ultra-wide View Type)
Setting distance (L)	34 to 49 mm (variable)	31 to 187 mm (variable)	67 to 142 mm (variable)	115 to 227 mm (variable)
Sensing range (H × V) 	5 × 4.6 mm to 9 × 8.3 mm (variable)	10 × 9.2 mm to 50 × 46 mm (variable)	50 × 46 mm to 90 × 83 mm (variable)	90 × 83 mm to 150 × 138 mm (variable)
Relation between setting distance and sensing range	Setting distance (L) 	Setting distance (L) 	Setting distance (L) 	Setting distance (L) 
Built-in lens	Focus: f15.65	Focus: f13.47	Focus: f6.1	
Object lighting method	Pulse lighting			
Object light source	Eight white LEDs	Thirty-six white LEDs	Twenty white LEDs	Seventy-two white LEDs
Optional lighting interface	No	Yes		No
Sensing element	1/3-inch CCD			
Shutter	Electronic shutter, shutter time: 1/500 to 1/8,000			
Power supply voltage	15 VDC (Supplied from Amplifier Unit.)	15 VDC, 48 VDC (Supplied from Amplifier Unit.)		
Current consumption	Approx. 200 mA	Approx. 350 mA (15 V: approx. 150 mA, 48 V: approx. 200 mA, including current when external light is connected)		
Dielectric strength	1,000 VAC, 50/60 Hz for 1 min			
Vibration resistance (destruction)	10 to 150 Hz, 0.35-mm single amplitude, 10 times each in X, Y, and Z directions for 8 min			
Shock resistance (destruction)	150 m/s ² , three times each in six directions (up/down, left/right, forward/backward)			
Ambient temperature range	Operating: 0 to 40°C, Storage: -20 to 65°C (with no icing or condensation)			
Ambient humidity range	Operating and storage: 35% to 85% (with no condensation)			
Ambient atmosphere	Must be free of corrosive gas.			
Connection method	Prewired, Standard cable length: 2 m			
Degree of protection (IEC 60529 standard)	IP65	ZFV-SC□□□□: IP65 ZFV-SC□□□□W: IP67		
Materials	Case: ABS, Mounting bracket: PBT			
Weight	Approx. 200 g (including mounting bracket and cord; packaged condition: approx. 300 g)	Approx. 270 g (including mounting bracket and cord; packaged condition: approx. 350 g)	Approx. 300 g (including mounting bracket and cord; packaged condition: approx. 380 g)	Approx. 600 g (including mounting bracket and cord; packaged condition: approx. 780 g)
Accessories	Mounting bracket (ZFV-XMF) (1), Ferrite core (2), Instruction sheet	Mounting bracket (ZFV-XMF2) (1), Ferrite core (2), Instruction sheet	Mounting bracket (ZFV-XMF2) (1), Ferrite core (2), Instruction sheet	Ferrite core (2), Instruction sheet
LED class (See note.)	Class 1	Class 2	Class 2	Class 1

Note : Applicable standards
IEC 60825-1: 1993, +A1: 1997, +A2: 2001, EN 60825-1: 1994, +A1: 2002, +A2: 2001

Amplifier Units

Item	ZFV-CA40	ZFV-CA45
Output method	NPN open collector, 30 VDC 50 mA max., residual voltage 1.2 V max.	PNP open collector, 50 mA max., residual voltage 1.2 V max.
Serial I/O	USB2.0	1 port, full-speed (12 Mbps) MINI-B
	RS-232C	1 port, 115200 bps max.
Inspection items	Patterns (PATTERN), Brightness (BRIGHT), Area (AREA), Width (WIDTH), Position (POSITION), Count (COUNT), Color inspection (HUE), Character (CHARA)	
Teaching area size	<ul style="list-style-type: none"> Patterns (PATTERN), Brightness (BRIGHT): Any rectangular area (256 × 256 max.) Area (AREA), Width (WIDTH), Position (POSITION), Count (COUNT), Color inspection (HUE), Character (CHARA): Any rectangular area (full screen max.) 	
Sensing area	Full screen	
Resolution	468 × 432 (H × V) max.	
Bank selection	Supported for 8 banks.	
Image input cycle	13 ms (Standard), 8 ms (FAST mode), 5 ms (MAX mode)	
Other functions	Control output switching: ON for OK or ON for NG, ON delay/OFF delay, One-shot output, "ECO" mode	
Connecting to ZS-DSU (See note 2.)	Image logging trigger	Stores NG images or all images.
	Sampling rate	ZFV measurement cycle (See note 1.)
	Number of logged images	Logs up to 128 images in series
	Number of connected Units	15 max. (ZFV: 5 Units max.)
	External bank function	Amplifier Unit setting data can be saved to the memory card as bank data. Reading bank data enables bank switching.
Output signals	(1) Control output (OUTPUT) (2) Enable output (ENABLE) (3) Error output (ERROR)	
Input signals	(1) Sync measurement input (TRIG)/Continuous measurement input (TRIG); switched from menu (2) Bank selection input (BANK1-3) (3) Object stationary teaching (TEACH)/Object motion teaching (TEACH); switched from menu	
Sensor Head interface	Digital interface	
Image display	TFT 1.8-inch LCD (Display dots: 557 × 234)	
Indicators	<ul style="list-style-type: none"> Judgment result indicator (OUTPUT, Color: orange) Inspection mode indicator (RUN, Color: green) Error indicator (ERR, Color: red) Ready status indicator (READY, Color: blue) 	
Operation interface	<ul style="list-style-type: none"> Cursor keys (up, down, left, right) Setting key (SET) Escape key (ESC) Operating mode switching (slide switch) Menu switching (slide switch) Teaching/Display switching key (TEACH/VIEW) Function keys (A to D, 4 inputs) 	
Power supply voltage	20.4 to 26.4 VDC (including ripple)	
Current consumption	800 mA max. (with Sensor Head connected)	
Dielectric strength	1,000 VAC, 50/60 Hz for 1 min between leads and Amplifier Unit case	
Noise immunity	1 kV, Pulse rise: 5 ns, Pulse width: 50 ns, Burst duration: 15 ms, Cycle: 300 ms	
Vibration resistance (destruction)	10 to 150 Hz, 0.1-mm single amplitude, 10 times each in X, Y, and Z directions for 8 min	
Shock resistance (destruction)	150 m/s ² , three times each in six directions (up/down, left/right, forward/backward)	
Ambient temperature range	Operating: 0 to 50°C, Storage: -25 to 65°C (with no icing or condensation)	
Ambient humidity range	Operating and storage: 35% to 85% (with no condensation)	
Ambient atmosphere	Must be free of corrosive gas.	
Degree of protection	IEC 60529, IP20	
Materials	Polycarbonate	
Weight	Approx. 300 g (including cord; packaged condition: 450 g)	
Accessories	Ferrite core (1), Instruction sheet	

Note 1: This is the sampling rate when logging images. To log measurement data only, use the ZS-DSU settings.

2: Restrictions exist depending on the versions of the connected devices. Ask your OMRON representative for details.

Dimensions

(Unit: mm)

■ Sensor Heads

ZFV-SC10

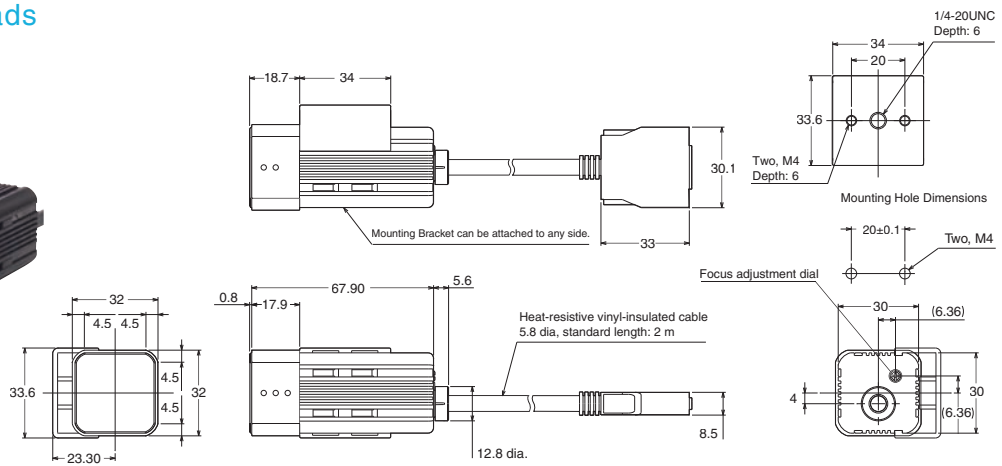

ZFV-SC50/SC50W

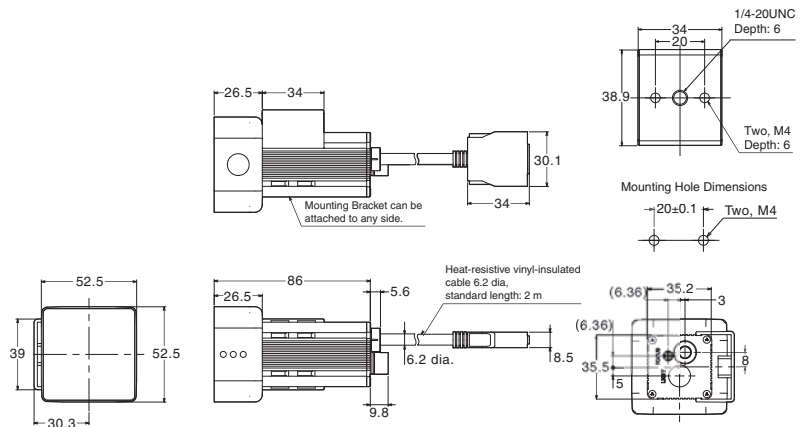

ZFV-SC90/SC90W

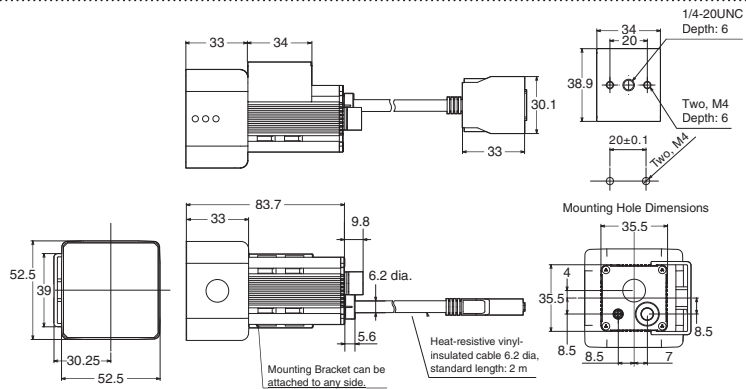

ZFV-SC150/SC150W

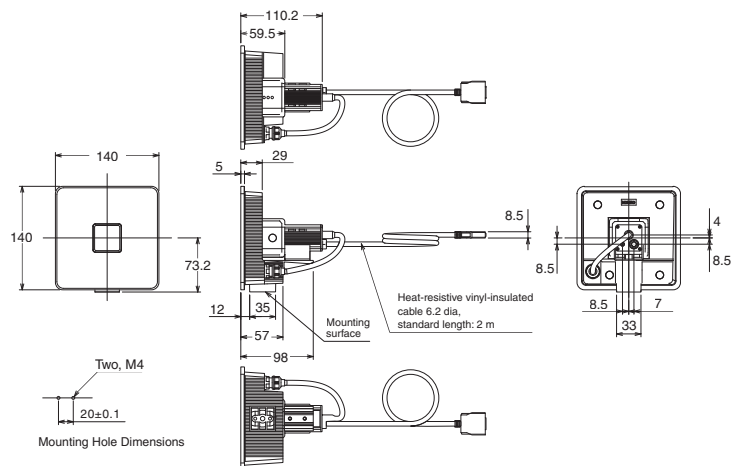
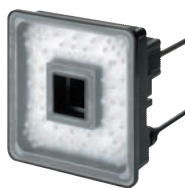

Amplifier Units

ZFV-CA4

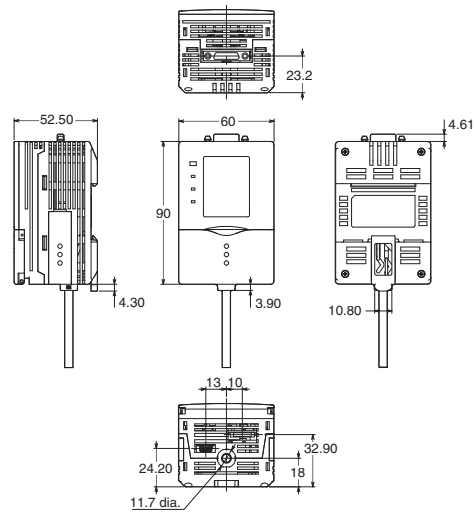

Optional Lighting

ZFV-LTL01

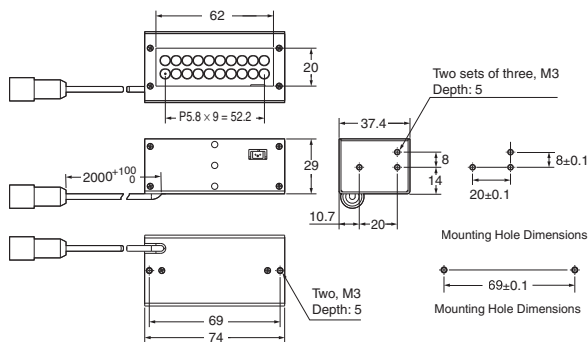

ZFV-LTL04

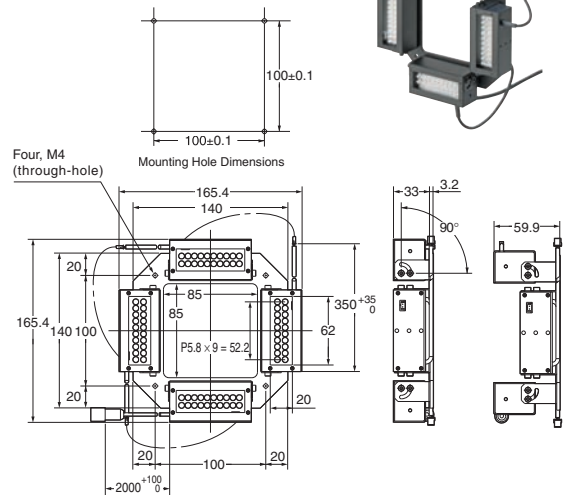

ZFV-LTL02

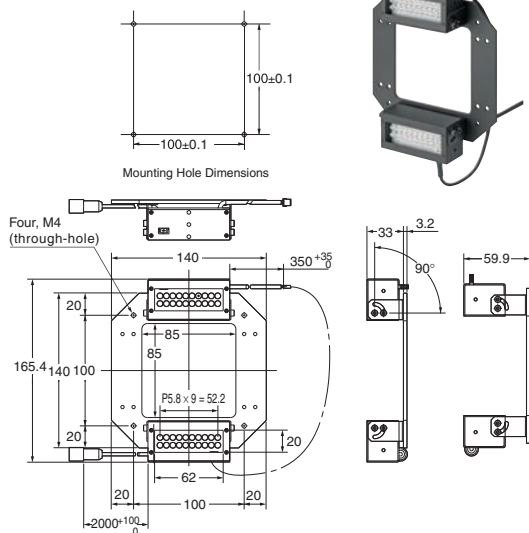

ZFV-LTF01

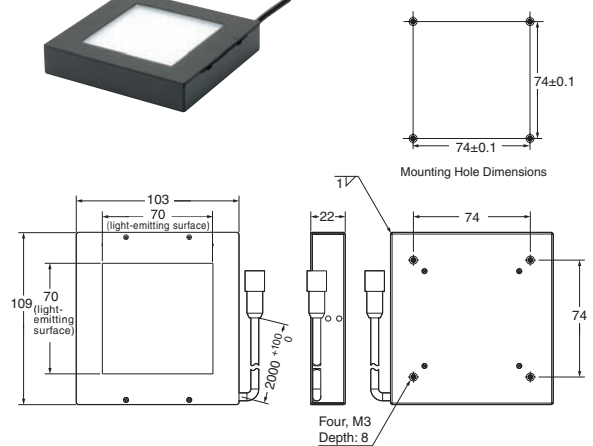

This document provides information mainly for selecting suitable models. Please read the User's Manual (Z240) carefully for information that the user must understand and accept before purchase, including information on warranty, limitations of liability, and precautions.

Note: Do not use this document to operate the Unit.

OMRON Corporation
Industrial Automation Company
Sensing Devices Division H.Q.
Application Sensors Division

Shiokoji Horikawa, Shimogyo-ku,
Kyoto, 600-8530 Japan
Tel: (81) 75-344-7068/Fax: (81) 75-344-7107

Regional Headquarters

OMRON EUROPE B.V.

Sensor Business Unit

Carl-Benz-Str. 4, D-71154 Nufringen,
Germany
Tel: (49) 7032-811-0/Fax: (49) 7032-811-199

OMRON ELECTRONICS LLC

One Commerce Drive Schaumburg,
IL 60173-5302 U.S.A.
Tel: (1) 847-843-7900/Fax: (1) 847-843-7787

OMRON ASIA PACIFIC PTE. LTD.

No. 438A Alexandra Road # 05-05/08 (Lobby 2),
Alexandra Technopark, Singapore 119967
Tel: (65) 6835-3011/Fax: (65) 6835-2711

OMRON (CHINA) CO., LTD.

Room 2211, Bank of China Tower,
200 Yin Cheng Zhong Road,
PuDong New Area, Shanghai, 200120, China
Tel: (86) 21-5037-2222/Fax: (86) 21-5037-2200

Authorized Distributor:

In the interest of product improvement,
specifications are subject to change without notice.

Read and Understand This Catalog

Please read and understand this catalog before purchasing the products. Please consult your OMRON representative if you have any questions or comments.

Warranty and Limitations of Liability

WARRANTY

OMRON's exclusive warranty is that the products are free from defects in materials and workmanship for a period of one year (or other period if specified) from date of sale by OMRON.

OMRON MAKES NO WARRANTY OR REPRESENTATION, EXPRESS OR IMPLIED, REGARDING NON-INFRINGEMENT, MERCHANTABILITY, OR FITNESS FOR PARTICULAR PURPOSE OF THE PRODUCTS. ANY BUYER OR USER ACKNOWLEDGES THAT THE BUYER OR USER ALONE HAS DETERMINED THAT THE PRODUCTS WILL SUITABLY MEET THE REQUIREMENTS OF THEIR INTENDED USE. OMRON DISCLAIMS ALL OTHER WARRANTIES, EXPRESS OR IMPLIED.

LIMITATIONS OF LIABILITY

OMRON SHALL NOT BE RESPONSIBLE FOR SPECIAL, INDIRECT, OR CONSEQUENTIAL DAMAGES, LOSS OF PROFITS, OR COMMERCIAL LOSS IN ANY WAY CONNECTED WITH THE PRODUCTS, WHETHER SUCH CLAIM IS BASED ON CONTRACT, WARRANTY, NEGLIGENCE, OR STRICT LIABILITY.

In no event shall responsibility of OMRON for any act exceed the individual price of the product on which liability is asserted.

IN NO EVENT SHALL OMRON BE RESPONSIBLE FOR WARRANTY, REPAIR, OR OTHER CLAIMS REGARDING THE PRODUCTS UNLESS OMRON'S ANALYSIS CONFIRMS THAT THE PRODUCTS WERE PROPERLY HANDLED, STORED, INSTALLED, AND MAINTAINED AND NOT SUBJECT TO CONTAMINATION, ABUSE, MISUSE, OR INAPPROPRIATE MODIFICATION OR REPAIR.

Application Considerations

SUITABILITY FOR USE

OMRON shall not be responsible for conformity with any standards, codes, or regulations that apply to the combination of products in the customer's application or use of the product.

At the customer's request, OMRON will provide applicable third party certification documents identifying ratings and limitations of use that apply to the products. This information by itself is not sufficient for a complete determination of the suitability of the products in combination with the end product, machine, system, or other application or use.

The following are some examples of applications for which particular attention must be given. This is not intended to be an exhaustive list of all possible uses of the products, nor is it intended to imply that the uses listed may be suitable for the products:

- Outdoor use, uses involving potential chemical contamination or electrical interference, or conditions or uses not described in this catalog.
- Nuclear energy control systems, combustion systems, railroad systems, aviation systems, medical equipment, amusement machines, vehicles, safety equipment, and installations subject to separate industry or government regulations.
- Systems, machines, and equipment that could present a risk to life or property.

Please know and observe all prohibitions of use applicable to the products.

NEVER USE THE PRODUCTS FOR AN APPLICATION INVOLVING SERIOUS RISK TO LIFE OR PROPERTY WITHOUT ENSURING THAT THE SYSTEM AS A WHOLE HAS BEEN DESIGNED TO ADDRESS THE RISKS, AND THAT THE OMRON PRODUCT IS PROPERLY RATED AND INSTALLED FOR THE INTENDED USE WITHIN THE OVERALL EQUIPMENT OR SYSTEM.

Disclaimers

CHANGE IN SPECIFICATIONS

Product specifications and accessories may be changed at any time based on improvements and other reasons.

It is our practice to change model numbers when published ratings or features are changed, or when significant construction changes are made. However, some specifications of the product may be changed without any notice. When in doubt, special model numbers may be assigned to fix or establish key specifications for your application on your request. Please consult with your OMRON representative at any time to confirm actual specifications of purchased product.

DIMENSIONS AND WEIGHTS

Dimensions and weights are nominal and are not to be used for manufacturing purposes, even when tolerances are shown.

ERRORS AND OMISSIONS

The information in this catalog has been carefully checked and is believed to be accurate; however, no responsibility is assumed for clerical, typographical, or proofreading errors, or omissions.

PERFORMANCE DATA

Performance data given in this catalog is provided as a guide for the user in determining suitability and does not constitute a warranty. It may represent the result of OMRON's test conditions, and the users must correlate it to actual application requirements. Actual performance is subject to the OMRON Warranty and Limitations of Liability.

PROGRAMMABLE PRODUCTS

OMRON shall not be responsible for the user's programming of a programmable product, or any consequence thereof.

COPYRIGHT AND COPY PERMISSION

This catalog shall not be copied for sales or promotions without permission.

This catalog is protected by copyright and is intended solely for use in conjunction with the product. Please notify us before copying or reproducing this catalog in any manner, for any other purpose. If copying or transmitting this catalog to another, please copy or transmit it in its entirety.